

VIDEO WALL MOUNTS

FOR 40-52 INCH PROFESSIONAL DISPLAYS

Vogel's Professional introduces modular video wall solution especially designed for 40 - 52 inch professional displays. With this modular concept you can create a video wall mount solution for almost every display.

Modular: always create a fit

With the modular concept you can create your own video wall solution for almost every display. Different sizes of interface wall plates and interface display strips are available.

Easy levelling and installation





Special diagonal mounting holes make it very easy to level the interface wall plate during installation. You can even fine tune it after installation.

Service position

Cables can be easily connected after installation. The service position also allows individual displays to be removed for maintenance or replacement

The key features of Video wall mounts:

- Quick & easy installation
- Limited number of components
- Create any combination possible
- Service functionality
- Cost effective solution per display

STEPS	VIDEO WALL MOUNTS
STEP 1 INTERFACE WALL PLATE 	 <div style="display: flex; justify-content: space-around;"> 1800 mm PFW 5818 2100 mm PFW 5821 2700 mm PFW 5827 3300 mm PFW 5833 </div>
STEP 2 INTERFACE DISPLAY STRIPS	 <div style="text-align: center;">  PFW 5905 </div>



PFW 5818 / PFW 5821 / PFW 5827 / PFW 5833

Interface wall plate

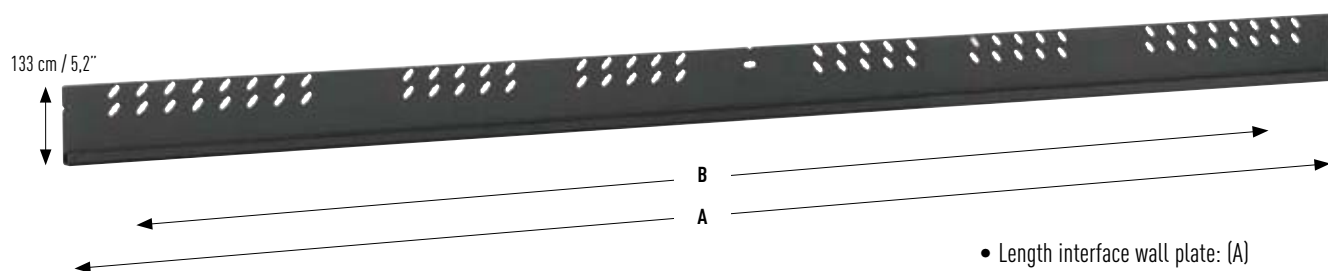

- Length interface wall plate: (A)
- Max fitment: (B)
- Built-in levelling function

PFW 5818

(A) = 1800 mm / (B) = 1720 mm

SIZE 103-133 cm / 40-52"

MAX. 160 kg / 352 lbs



PFW 5821

(A) = 2100 mm / (B) = 2020 mm

103-133 cm / 40-52"

160 kg / 352 lbs



PFW 5827

(A) = 2700 mm / (B) = 2620 mm

103-133 cm / 40-52"

160 kg / 352 lbs



PFW 5833

(A) = 3300 mm / (B) = 3220 mm

103-133 cm / 40-52"

160 kg / 352 lbs

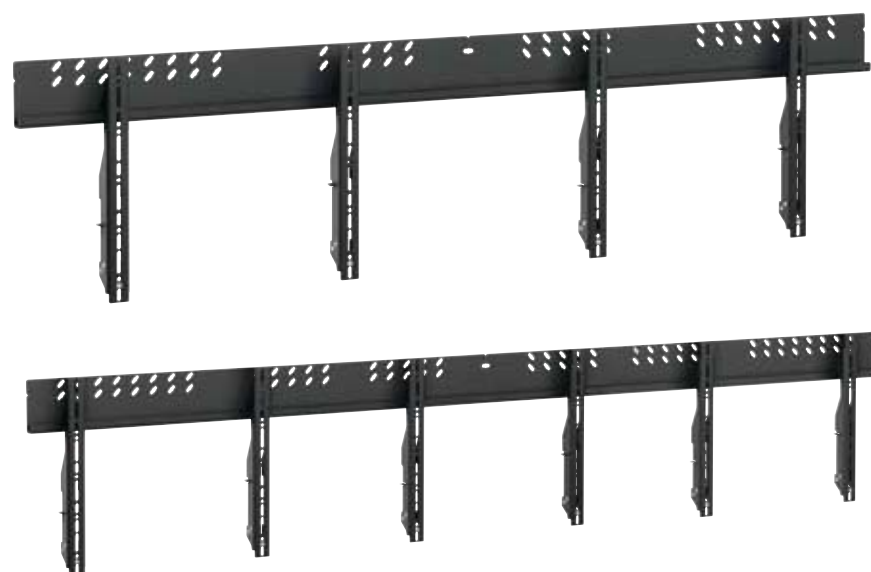

PFW 5905

Interface display strips (set of 2)

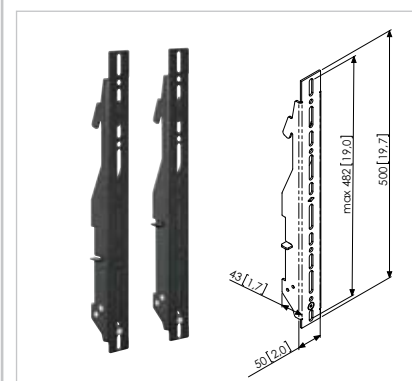

SIZE 103-133 cm / 40-52"

MAX. 160 kg / 352 lbs



- Max fitment 480 mm
- Vertical levelling
- Built-in service position

Type nr.	☑	Max. weight				Length	Max. fitment	Colour
		Safety VSS-3]¹	GS/TÜV certified]²	Safety VSS-5]³	GS/TÜV certified]³			
PFW 5818	103-133 cm / 40-52"	250 kg / 550 lbs	-	160 kg / 352 lbs	-	1800 mm	1720 mm	●
PFW 5821	103-133 cm / 40-52"	250 kg / 550 lbs	-	160 kg / 352 lbs	-	2100 mm	2020 mm	●
PFW 5827	103-133 cm / 40-52"	250 kg / 550 lbs	-	160 kg / 352 lbs	-	2700 mm	2620 mm	●
PFW 5833	103-133 cm / 40-52"	250 kg / 550 lbs	-	160 kg / 352 lbs	-	3300 mm	3220 mm	●
PFW 5905	103-133 cm / 40-52"	250 kg / 550 lbs	-	160 kg / 352 lbs	-	500 mm	480 mm	●

]¹ VSS-3: Vogel's Safety Standard = tested to 3x the specified weight •]² VSS-5: Vogel's Safety Standard = tested to 5x the specified weight. In some countries a 5x overload test is required for professional use •]³ GS/TÜV certified = tested to 3x or 5x the specified weight
Visit www.vogels.com for more information.